

ZAXIS-3 series

HITACHI

ZAXIS
200



HYDRAULIC EXCAVATOR

- **Model Code** : ZX200-3 / ZX200LC-3 / ZX210H-3 / ZX210LCH-3
ZX210K-3 / ZX210LCK-3
- **Engine Rated Power** : 122 kW (164 HP)
- **Operating Weight** : ZX200-3 : 19 800 kg / ZX200LC-3 : 20 400 kg
ZX210H-3 : 21 000 kg / ZX210LCH-3 : 21 400 kg
ZX210K-3 : 21 900 kg / ZX210LCK-3 : 22 300 kg
- **Backhoe Bucket** : SAE, PCSA Heaped: 0.51 - 1.20 m³
CECE Heaped: 0.45 - 1.00 m³

The Power to Perform

The ZAXIS-3 series is a new generation of excavators designed to provide more efficient power, productivity and improved operator comfort. By listening carefully to the wishes of the end-user, HITACHI not only understands your business, but also provides the reliable solutions you've been looking for.

NEW AND IMPROVED

- **Performance:**
12% higher production
- **Comfort:**
Excellent visibility
Enhanced controllability
Lower noise level
- **Reduced running costs:**
Lower fuel consumption per m³
Improved durability and reliability
- **New equipment:**
Rear view camera (optional)
Theft deterrent system



Productivity

- New E-mode
 - New hydraulic system HIOS III
 - Hydraulic boosting system
 - Enhanced boom recirculation system
 - New electronic controlled diesel engine
- Page 4-5**

Operator comfort

- High visibility inside cab
 - Short stroke levers
 - Wide foot space
 - Comfort designed seat
 - Improved controllability and operator comfort
- Page 6-7**

Multi function monitor

- Maintenance support
 - Attachment support system
 - Rear view camera (optional)
 - Theft deterrent system
 - Fuel consumption monitoring
- Page 8-9**

Durability and reliability

- Strengthened undercarriage
 - Strengthened X beam
 - Improved idler brackets
 - Strengthened front attachment
- Page 10-11**

Maintenance

- Parallel arrangement of the cooling pack
 - Conveniently located inspection points
- Page 12-13**

Safety measures

- CRES II cab
 - Cab right protection bars
 - Pilot control shut-off lever
 - Engine shut-off switch
- Page 14**

Environment measures

- Array of low noise mechanisms
 - Ecological design
- Page 15**

Parts & service

Page 16-17

Varios versions

- Heavy-duty version H-series
 - Demolition version K-series
- Page 18-19**

Specifications

Page 20-27

- The new engine complies with the Emission Regulations U.S EPA Tier 3, and EU Stage III A
- The advanced low noise design complies with the coming EU noise regulation 2000 / 14 / EC, STAGE II

Notes : Some of the pictures in this catalog show an unmanned machine with attachments in an operating position. These were taken for demonstration purposes only and the actions shown are not recommended under normal operating conditions.



Boosted Productivity

New hydraulic system HIOS III and new OHC 4-valve diesel engine were developed for ZAXIS-3. These advanced technologies are at work to yield bigger output with higher fuel efficiency.

More production, less fuel consumption

Increased Production

A combination of the hydraulic system (HIOS*III) and new OHC** 4-valve engine allows the efficient use of hydraulic pressure to increase speeds of actuators and boost production with higher fuel efficiency. The productivity is increased 12% in comparison to previous model ZAXIS-1.

*Human & Intelligent Operation System

**OverHead Camshaft

New E-mode

The new E mode, H/P mode and P mode can be selected to suit job needs. The new E mode can save fuel consumption by up to 13% compared to the previous P mode, while yielding similar production.

Increase in Swing Torque and Traction Force

Swing torque and traction force are increased significantly.

-Swing torque 13% UP

-Traction force 11% UP

Sophisticated Travel Control; At climbing or steering, when the machine needs more traction force, the engine speed automatically increases which makes the machine faster.

Efficient hydraulic control - HIOS III

ZAXIS-1 adapted HIOS II hydraulic system that is suitable for fine controllability by the operators. Continuously HITACHI developed new advanced hydraulic technology HIOS III for ZAXIS-3. In addition to the fine controllability this new system increases the efficiency of hydraulic circuit and increases speed of actuators.

The Hydraulic Boosting System

In arm roll-in and boom raise operation, excess pressurized oil is delivered from boom cylinder rod side to arm cylinder bottom side to increase flow rate giving 20% higher arm roll-in speed. Excess pressurized oil from boom cylinder rod side is delivered to arm cylinder bottom side through a regenerative valve to increase flow rate for productive operation.

Enhanced Boom Recirculation System

In combined operation of boom lower and arm, pressure oil from boom cylinder bottom side is delivered to boom cylinder rod side, assisted by boom weight, for boom lowering. At the same time, pressure oil from the pump is delivered to the arm cylinder for arm movement. This mechanism allows an increase of speed in combined operation of 15%.

Development concept of new engine

OHC 4-Valve Engine

The new OHC 4-valve diesel engine is developed and built to comply with the rigorous Emission Regulations enforced in 2006 in U.S and EU. This new engine contributes to environmental preservation. At the same time it realizes high durability and low fuel consumption by adapting the latest advanced engine technology.



Common Rail Type Fuel Injection System

Electronic control common rail type fuel injection system drives an integrated fuel pump at an ultrahigh pressure to distribute fuel to each injector per cylinder through a common rail. This enables optimum combustion to generate big horsepower, and reduce PM* (diesel plume) and fuel consumption.

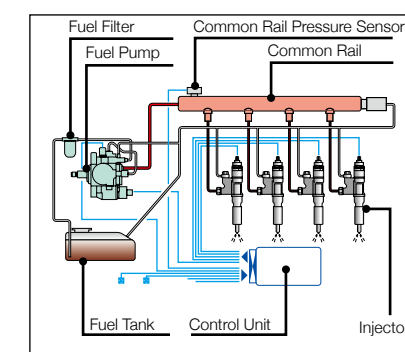

Cooled EGR** System

Exhaust gas is partially mixed with intake air to lower combustion temperature for reducing NOx and fuel consumption. What's more, the EGR cooler cools down exhaust gas to increase air concentration for complete combustion, reducing PM* (diesel plume).

*Particulate Matter

**Exhaust Gas Recirculation

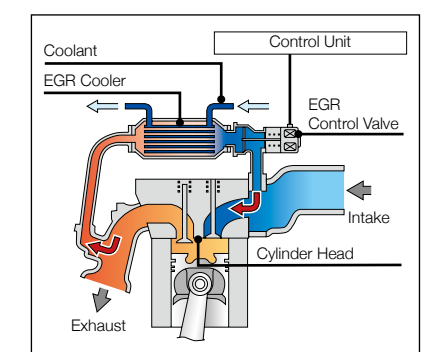

A New Standard in Operator Comfort

The operator's seat of the ZAXIS-3 series gives the operator an excellent view of the jobsite. On the widescreen color LCD monitor the operator can see machine conditions. Ample legroom, short stroke levers and a large seat ensure optimum working conditions for the operator during long hours.



The ZAXIS-3 series cab has been redesigned to meet demands of customers. From the operator's seat the operator has an excellent view of the jobsite. On the widescreen color LCD monitor the operator can see machine conditions and with the rear view camera (optional), what is behind the machine. Ample legroom, short stroke levers and a suspension seat (optional) with heating ensure optimum working conditions. The seat features horizontal, vertical adjustments and has a backrest contoured for comfort, with a HITACHI logo.



Wide adjustable armrests and a retractable seat belt are included. Short stroke levers allow for continuous operation with less fatigue. Three switches on the lever (optional) can be set to operate attachments other than buckets. The cab is pressurized to keep out dust. Noise and vibrations are kept to a minimum due to the elastic mounts, filled with silicone oil, the cab rests on.

Visibility is improved especially for the right downward view. Sliding windows on the front and side enable direct communication between operator and other workers. Foot space has increased and travel pedals have been redesigned for easier operation. A flat floor allows for easy cleaning. Ergonomic controls and switches, fully automatic air conditioner and a radio complete the package.

Embedded Information Technology

The ZAXIS-3 series is equipped with a widescreen color LCD monitor with adjustable contrast for day and night shifts. With the monitor the operator can check maintenance intervals, select work modes, monitor fuel consumption, and connect to the rear view camera (optional). A theft deterrent system and multi-language selection is also available.

Multi function monitor



The color LCD monitor, located in the cab, indicates coolant temperature, fuel level, and maintenance data. It also allows one-touch adjustment of the attachment. The display can also be adjusted to day or night shift.

Maintenance support

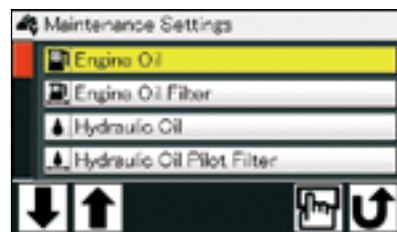

Replacement timing of hydraulic oil and fuel filters is alerted to the operator through the LCD monitor according to the schedule preset by the user each time when turning the key switch. The scheduled maintenance can prevent the failure of the machine.

Attachment support system (work mode selector)



When replacing the attachment, oil flow adjustment can automatically be done by one touch on the work mode selection display on the LCD monitor. Minor adjustments of oil flow is possible if necessary.

Multi-language selection



The menu allows selection from 12 languages.



Theft deterrent system



The electronic immobiliser requires the entry of an encryption code to the multifunctional monitor each time when starting the engine to prevent theft and vandalism.

Rear view camera (optional)



The widescreen color LCD, teamed up with the rear view camera on the counterweight, gives the operator unobstructed rearward viewing. The rear view camera automatically works when traveling, and can also be manually turned on with a select switch on the monitor.

Fuel consumption monitoring



Fuel consumption per operating hour is computed, and the result is displayed on the LCD monitor. This information suggests refuelling timing, and guides energy-saving operation and efficient job management.

A Solid Base for a Long Life

HITACHI's technology is built on a wealth of experience and know-how from limestone sites and quarries around the world. The undercarriage of the ZAXIS 200 has become much stronger. Improved construction and enlarged box sections, a track undercover plate that protects the center joint and hydraulic hoses make this machine more durable.



Strengthened undercarriage

Upper rollers and upper roller brackets are increased in size for higher durability. Track links are thickened and reshaped for higher durability and rigidity.



Strengthened X beam and side frames

The X-beam is strengthened by the improved construction and enlarged box sections. The section is increased in strength up to 35% (maximum). Top and bottom plates of the X-beam use monolithic plates, instead of conventional welded four plates. This eliminates welding to strengthen the X-beam.

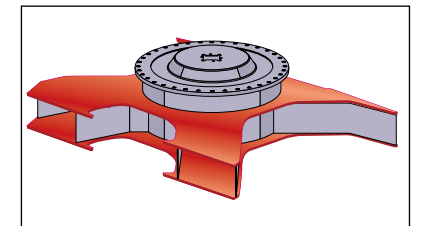

Improved idler brackets

The idler bracket reinforcing plate is thickened greatly for higher durability to prevent the opening of the idler bracket. The track link disengagement preventive plate, located immediately behind the idler bracket, extends its top to prevent track link disengagement and increase durability.

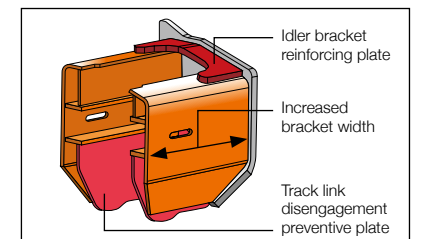

Strengthened front attachment

The boom top bracket is strengthened by using high-tensile steel. At arm-bucket joint, the arm top is hardened with WC thermal spraying (Tungsten-Carbide) for greater wear resistance at its contact surface with bucket, reducing jerking. Reinforced resin thrust plates designed to reduce noise and resist wear.

The new HN bushings, containing "solid molybdenum-based lubricant", are utilized at the boom-arm joint and arm cylinder mounting area for better lubrication and higher durability. (At other joints, conventional HN bushings are also utilized.)

The boom foot is enlarged for higher strength. This improvement increases the durability and reliable under heavy-duty operation.



New HN bushing



WC Thermal spraying



Reinforced resin thrust plates

Simplified Maintenance

The ZAXIS-3 series meet customer demands for simplified maintenance. Regular maintenance is the key for keeping equipment in top condition, which can help to prevent costly downtime. In addition, a regular serviced machine has higher residual value. There are many service features to be found on the ZAXIS-3 series.



Parallel arrangement of the cooling pack

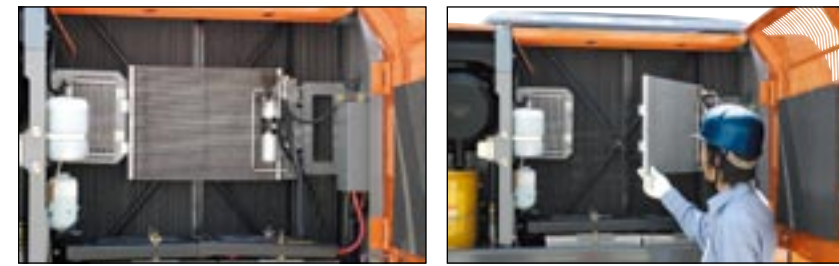

The oil cooler, radiator and intercooler are laid out in a parallel arrangement, instead of the conventional in-line arrangement. This parallel arrangement is significantly easier to clean around the engine. The air conditioner condenser can be opened for easy cleaning of the condenser and the radiator located behind.

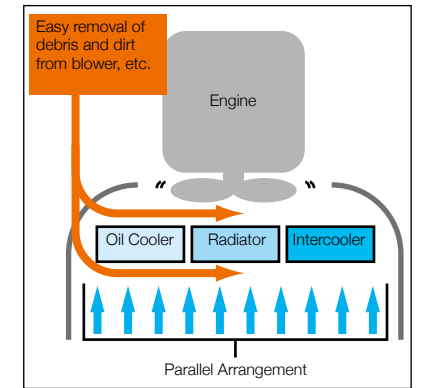

Conveniently located inspection points



Wide doors give access, from ground level, to the fuel filter, water separator and engine oil filter. A large handrail, steps and anti-skid plates lead to the engine cover. The engine oil pan is fitted with a drain coupler. When draining, an associated drain hose is connected to the drain coupler. The drain coupler is reliable, avoiding oil leakage and vandalism.

The fresh air filter for the air conditioner is relocated to cab door side from conventional location behind the operator seat. This allows easy cleaning and replacement of the fresh air filter, like the air circulation filter inside the cab.

Extended oil and filter change intervals

Front Pin Lubricating Intervals and Consumables Replacement		
		New ZAXIS 200
Lubricant	Bucket	500 h
	Boom Foot	500 h
	Front	500 h
Consumables	Engine Oil	500 h
	Engine Oil Filter	500 h
	Hydraulic Oil	5 000 h
	Hydraulic Oil Filter	1 000 h
	Fuel Filter	500 h

The oil and filter change intervals have been extended considerably, reducing maintenance time and expenses. Engine oil consumption is lower. Hydraulic oil can be used up to 5 000 hours.

Safety Features

Ensuring the safety of the operator and other workers on the jobsite is an important concern for HITACHI. That is why the ZAXIS-3 series has a number of safety features including a new reinforced cab and shut-off mechanisms for engine and pilot controls.

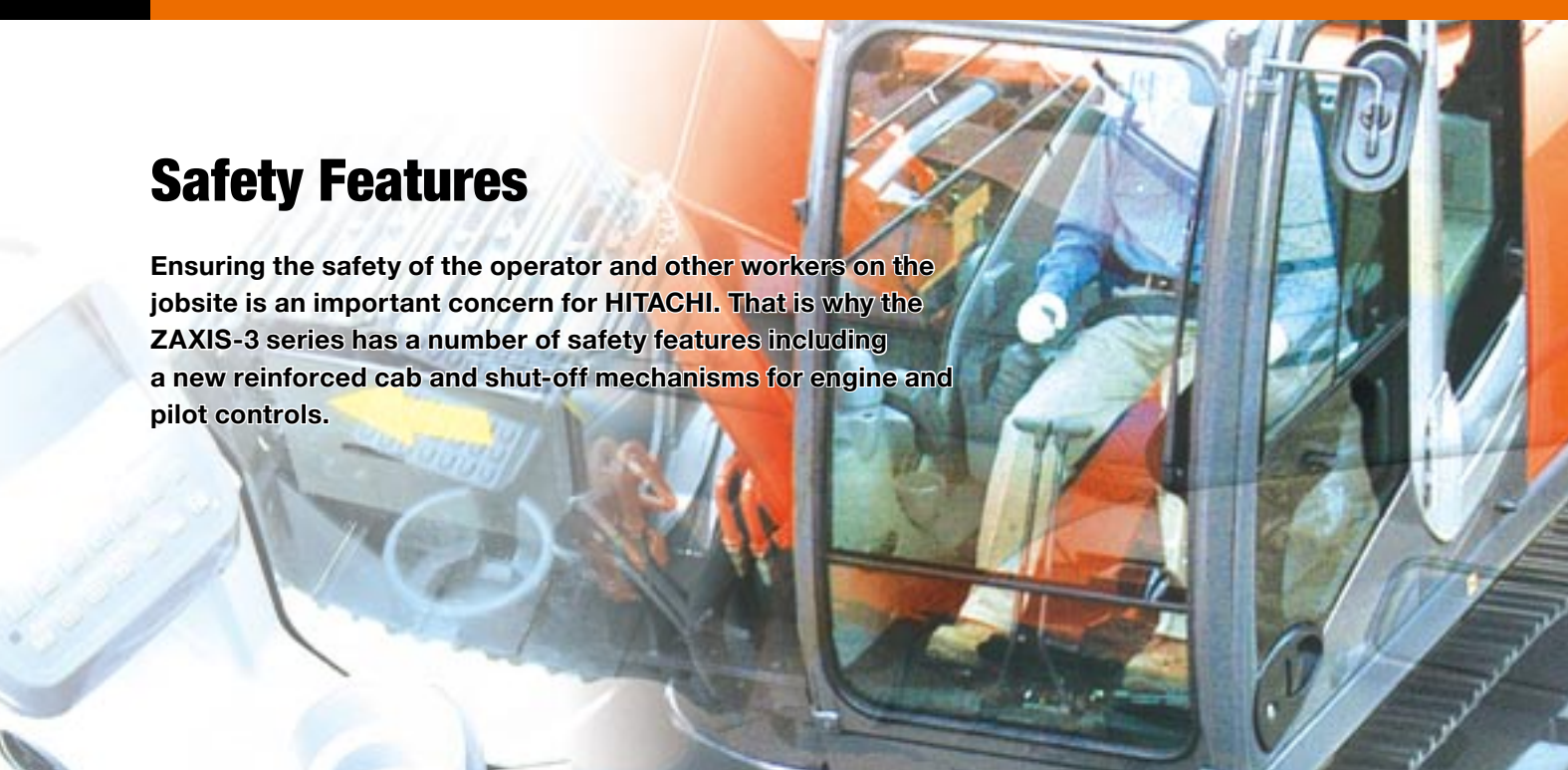

CRES II cab

The CRES II cab is designed to help with "just in case" protection for the operator. Safety in case of tipping is improved. The cab upper side edge can withstand 2.5-fold loading up to 200 mm deformation causes.

withstanding load : 2.5-fold increase



Additional features

Cab right protection bars



Evacuation hammer



Pilot control shut-off lever

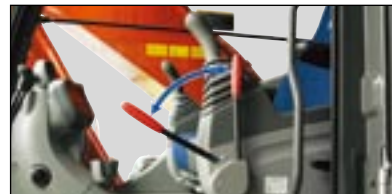

Other features include a retractable seatbelt, evacuation hammer and emergency engine shut-off switch. A shut-off lever for pilot control helps to prevent unintentional movements. In addition a Falling Object Protective Structure (FOPS) guard is optionally available. For the cab windows there is a choice of laminated or tempered glass.

Environmental Features

HITACHI takes its responsibility when it comes to the environment. Our production facilities have ISO 14001 certification. The HITACHI machine is lead free and has a low-noise design, therefore HITACHI customers get one of the most environmentally considerate hydraulic excavators available today.

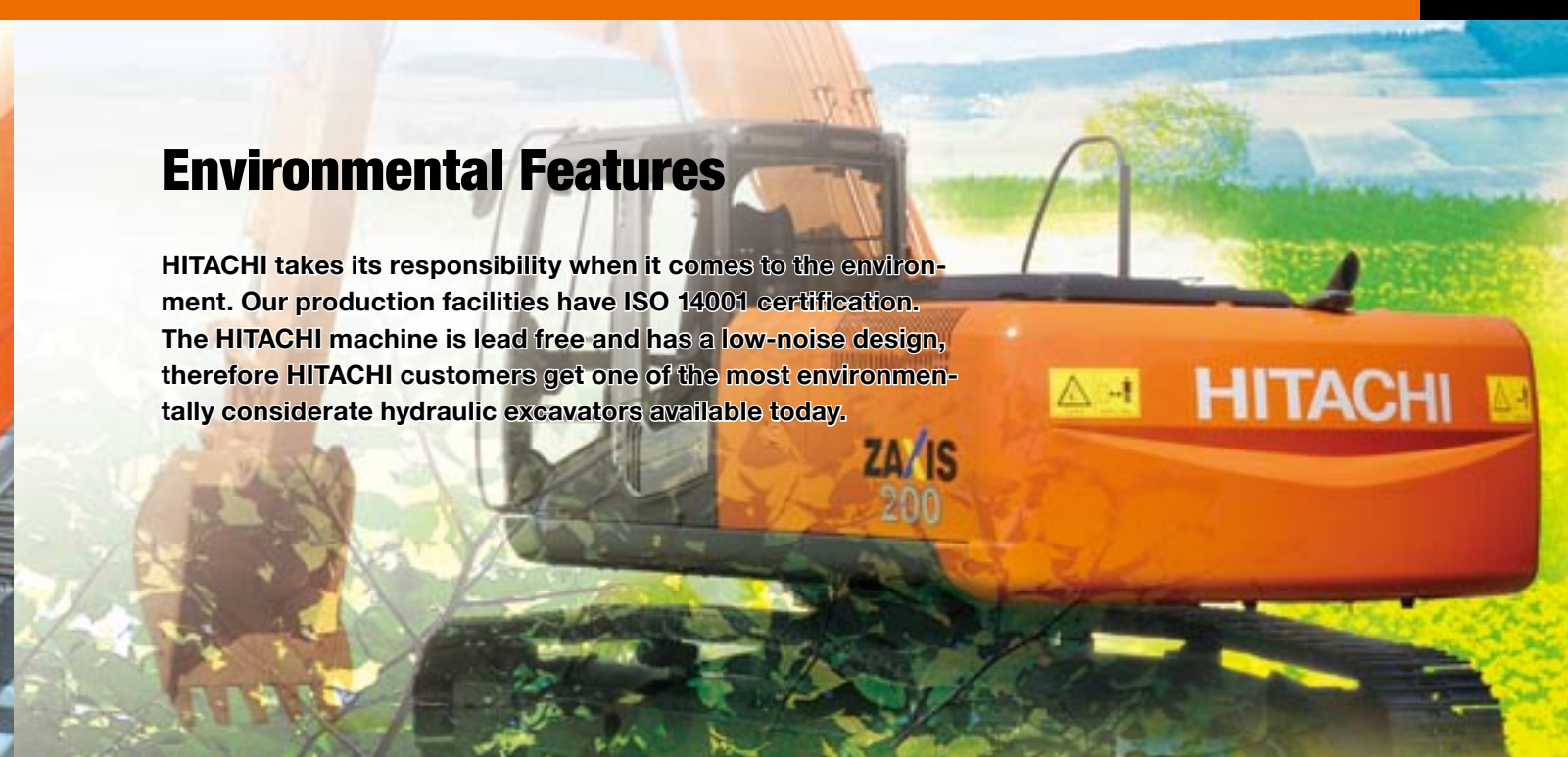

A cleaner machine

The ZAXIS-3 series is equipped with a clean but powerful engine to comply with Tier 3, and Stage III A. An engine emission regulations effective in the U.S. EPA and European Union from 2006. Exhaust gas is partly re-combusted to reduce particulate matter (PM) output and lower nitrogen oxide (NOx) levels.



A quieter machine

A number of features make this machine quieter. First, isochronous control of the engine speed means a restriction of engine speed during no-load and light-duty operation to suppress sound. Second, a fan with curved blades reduces air resistance and air flow noise. Third, a time-tested muffler suppresses engine noise significantly. This advanced low noise design complies with the 2000 / 14 / EC, Stage II, directive effective in the European Union from 2006.



A recyclable machine

Over 97% of the ZAXIS-3 series can be recycled. All resin parts are marked to facilitate recycling. The machine is completely lead-free. The radiator and oil cooler are made from aluminium and all wires are lead-less. In addition, biodegradable hydraulic oil is available for jobsites where special environmental care is required.



Parts & Service

Over the years, we have gained experience in one of the most competitive service markets in the world - Japan. Using our know-how in dealing directly with customers, we have created a worldwide support system that is highly capable.



Machine includes optional equipment installed by customer.

Parts

HITACHI only offers genuine high quality parts. We guarantee that these parts have high performance and long life. We manage around 1 000 000 types of parts all around the world. They are designed and built to be the best match for your HITACHI equipment. HITACHI has a global parts distribution network that makes sure you get what you need as quickly as possible. We have more than 150 dealers worldwide who provide the closest support for your needs. In most cases, your dealer will have the replacement part that you require. If a dealer does not have a certain part, he can order it from four fully stocked parts depots located across the world. These distribution centres are all connected by a on-line system that gives them access to shared information on stocks, such as the number and type of available parts. The depots, which in turn are stocked by a parts center in Japan, minimize delivery time and enable you to get your parts as efficiently and quickly as possible.



Service

Our goal is to “keep customer equipment at a maximum performance level”. To fulfil this goal, we have set more than 150 dealers all over the world. They have highly trained technicians, and provide a number of support programs. HITACHI provides a unique extended warranty program called HITACHI Extended Life Program, or HELP.

To minimize downtime during troubleshooting, we developed a PDA based diagnostic system called “Dr.ZX”. To keep our customers’ equipment in top running shape, good service is indispensable. We believe personnel training is the key to providing the best service.

If you would like more information regarding parts and/or service, please ask your nearest HITACHI dealer. Not all programs and/or services are available in every market or region.

Base Machine for Doing a Wide Range of Jobs.

Can be used with a wide range of hydraulic attachments.
Options include large-capacity additional pump along with piping and components for the attachments.

Heavy-Duty Version H-Series

ZAXIS210H / ZAXIS210LCH

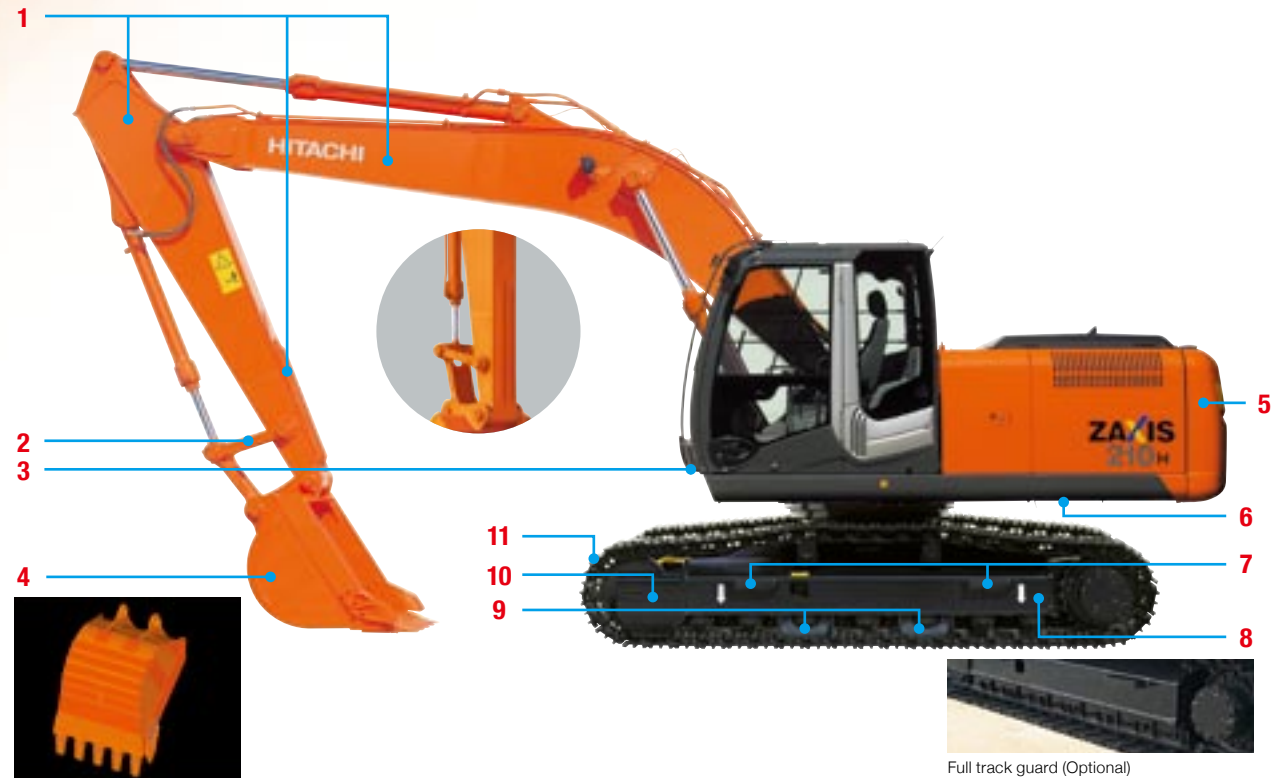

1 Reinforced thick steel front section. (H-boom / H-arm)
Thicker steel arm end.
Damage prevention plate and square bars.

2 Reinforced link B.

3 Front glass lower guard.

4 H-reinforced bucket.
Thicker steel.
Additional lateral plate.
Additional reinforcement plates on cutting edge section.

5 4 750 kg counterweight.

6 6.0 mm thickness undercover.

7 Reinforced side step. (bolt mounted)

8 Reinforced lower flange.

9 Reinforced track guard. (2 units each side)

10 Reinforced idler bracket.

11 600 mm reinforced triple grouser shoe.

Full track guard (Optional)

Demolition Version K-Series

ZAXIS210K / ZAXIS210LCK



1 Reinforced bucket cylinder.

2 Attachment basic piping.

3 Damage prevention plate.

4 Reinforced link B for demolition.

5 K-reinforced bucket.

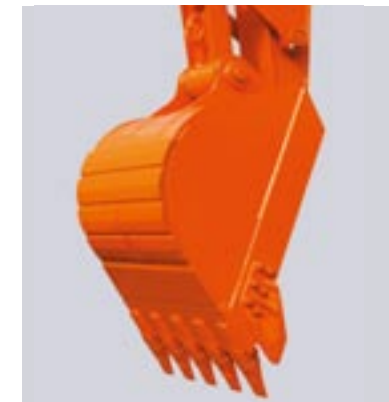

6 Front glass lower guard.

7 6.0 mm thickness undercover.

8 Reinforced idler bracket.

9 600 mm reinforced triple grouser shoe.

10 K-cab. (CRES II cab with overhead window & guard)



11 Twin wiper.

12 High-performance full-flow filter. (with restriction indicator)

13 5 350kg counterweight.

14 Reinforced side step. (bolt mounted)

15 Reinforced lower flange.

16 Track undercover.

OPTION

- Accessories for breaker
- Accessories for breaker & crusher
- Accessories for 2 speed selector
- Front glass upper guard
- Small radius swing bracket
- Pilot accumulator

*Notes: Photo shown model equipped with optional accessories for breaker and crusher.
Total weight of attachments to be mounted is from a standpoint of machine stability. For more details, contact your distributor.*

ENGINE

Model.....	Isuzu AI-4HK1X
Type	4-cycle water-cooled, direct injection
Aspiration.....	Turbocharged, intercooled
No. of cylinders	4
Rated power	
ISO 9249, net	122 kW (164 HP) at 2 000 min ⁻¹ (rpm)
EEC 80/1269, net ...	122 kW (164 HP) at 2 000 min ⁻¹ (rpm)
SAE J1349, net	122 kW (164 HP) at 2 000 min ⁻¹ (rpm)
Maximum torque	655 N·m (67 kgf·m) at 1 500 min ⁻¹ (rpm)
Piston displacement....	5.193 L
Bore and stroke.....	115 mm x 125 mm
Batteries.....	2 x 12 V / 88 Ah

HYDRAULIC SYSTEM

- Work mode selector
 - Digging mode / Attachment mode
 - Engine speed sensing system
- Main pumps..... 2 variable displacement axial piston pumps
- Maximum oil flow... 2 x 212 L/min
- Pilot pump..... 1 gear pump
- Maximum oil flow... 30 L/min

Hydraulic Motors

Travel	2 variable displacement axial piston motors
Swing.....	1 axial piston motor

Relief Valve Settings

Implement circuit.....	34.3 MPa (350 kgf/cm ²)
Swing circuit.....	34.3 MPa (350 kgf/cm ²)
Travel circuit	34.3 MPa (350 kgf/cm ²)
Pilot circuit	3.9 MPa (40 kgf/cm ²)
Power boost	36.3 MPa (370 kgf/cm ²)

Hydraulic Cylinders

High-strength piston rods and tubes. Cylinder cushion mechanisms provided in boom and arm cylinders to absorb shock at stroke ends.

Dimensions

	Quantity	Bore	Rod diameter
Boom	2	120 mm	85 mm
Arm	1	135 mm	95 mm
Bucket	1	115 mm	80 mm

Hydraulic Filters

Hydraulic circuits use high-quality hydraulic filters. A suction filter is incorporated in the suction line, and full-flow filters in the return line and swing/travel motor drain lines.

CONTROLS

Pilot controls. Hitachi's original shockless valve.

Implement levers	2
Travel levers with pedals	2

UPPERSTRUCTURE**Revolving Frame**

Welded sturdy box construction, using heavy-gauge steel plates for ruggedness. D-section frame for resistance to deformation.

Swing Device

Axial piston motor with planetary reduction gear is bathed in oil. Swing circle is single-row, shear-type ball bearing with induction-hardened internal gear. Internal gear and pinion gear are immersed in lubricant. Swing parking brake is spring-set/hydraulic-released disc type.

Swing speed	13.3 min ⁻¹ (rpm)
-------------------	------------------------------

Operator's Cab

Independent spacious cab, 1 005 mm wide by 1 675 mm high, conforming to ISO* Standards. Reinforced glass windows on 4 sides for visibility. Front windows (upper and lower) can be opened. Reclining seat with armrests; adjustable with or without control levers.

* International Standardization Organization

UNDERCARRIAGE**Tracks**

Tractor-type undercarriage. Welded track frame using selected materials. Side frame welded to track frame. Lubricated track rollers, idlers, and sprockets with floating seals.

Track shoes with triple grousers made of induction-hardened rolled alloy. Heat-treated connecting pins with dirt seals. Hydraulic (grease) track adjusters with shock-absorbing recoil springs.

Numbers of Rollers and Shoes on Each Side

Upper rollers.....	2
Lower rollers.....	7 : ZX200-3 / ZX210H-3 / ZX210K-3 8 : ZX200LC-3 / ZX210LCH-3 / ZX210LCK-3
Track shoes.....	46 : ZX200-3 / ZX210H-3 / ZX210K-3 49 : ZX200LC-3 / ZX210LCH-3 / ZX210LCK-3
Track guard	1 : ZX200-3 / ZX200LC-3 / ZX210K-3 / ZX210LCK-3 2 : ZX210H-3 / ZX210LCH-3

Travel Device

Each track driven by 2-speed axial piston motor through planetary reduction gear for counterrotation of the tracks. Sprockets are replaceable.

Parking brake is spring-set/hydraulic-released disc type. Travel shockless relief valve built in travel motor absorbs shocks when stopping travel.

Automatic transmission system: High-Low.

Travel speeds	High : 0 to 5.5 km/h Low : 0 to 3.5 km/h
---------------------	---

Maximum traction force....	203 kN (20 700 kgf)
----------------------------	---------------------

Gradeability	35° (70%) continuous
--------------------	----------------------

WEIGHTS AND GROUND PRESSURE**ZX200-3:**

Equipped with 5.68 m boom, 2.91 m arm and 0.80 m³ bucket (SAE, PCSA heaped).

Shoe type	Shoe width	Operating weight	Ground pressure
Triple grouser	600 mm	19 800 kg	44 kPa (0.45 kgf/cm ²)
	700 mm	20 200 kg	39 kPa (0.40 kgf/cm ²)
	800 mm	20 500 kg	34 kPa (0.35 kgf/cm ²)
Triangular	760 mm	20 900 kg	36 kPa (0.37 kgf/cm ²)
Flat	600 mm	20 700 kg	46 kPa (0.47 kgf/cm ²)

ZX200LC-3:

Equipped with 5.68 m boom, 2.91 m arm and 0.80 m³ bucket (SAE, PCSA heaped).

Shoe type	Shoe width	Operating weight	Ground pressure
Triple grouser	600 mm	20 400 kg	42 kPa (0.43 kgf/cm ²)
	700 mm	20 800 kg	37 kPa (0.38 kgf/cm ²)
	800 mm	21 100 kg	32 kPa (0.33 kgf/cm ²)
Triangular	760 mm	21 500 kg	34 kPa (0.35 kgf/cm ²)
Flat	600 mm	21 300 kg	44 kPa (0.45 kgf/cm ²)

ZX210H-3:

Equipped with 5.68 m H-boom, 2.91 m H-arm and 0.80 m³ H-bucket (SAE, PCSA heaped).

Shoe type	Shoe width	Operating weight	Ground pressure
Reinforced Triple grouser	600 mm	21 000 kg	47 kPa (0.48 kgf/cm ²)

ZX210LCH-3:

Equipped with 5.68 m H-boom, 2.91 m H-arm and 0.80 m³ H-bucket (SAE, PCSA heaped).

Shoe type	Shoe width	Operating weight	Ground pressure
Reinforced Triple grouser	600 mm	21 400 kg	44 kPa (0.45 kgf/cm ²)

ZX210K-3:

Equipped with 5.68 m K-boom, 2.91 m K-arm and 0.80 m³ K-bucket (SAE, PCSA heaped).

Shoe type	Shoe width	Operating weight	Ground pressure
Reinforced Triple grouser	600 mm	21 900 kg	49 kPa (0.50 kgf/cm ²)

ZX210LCK-3:

Equipped with 5.68 m K-boom, 2.91 m K-arm and 0.80 m³ K-bucket (SAE, PCSA heaped).

Shoe type	Shoe width	Operating weight	Ground pressure
Reinforced Triple grouser	600 mm	22 300 kg	46 kPa (0.47 kgf/cm ²)

Weight of the basic machines [including 4 350 kg, 4 750 kg H-type, or 5 350 kg K-type counterweight and triple grouser shoes, excluding front-end attachment, fuel, hydraulic oil, engine oil and coolant etc.] are:

ZX200-3	15 400 kg with 600 mm shoes
ZX200LC-3.....	16 000 kg with 600 mm shoes
ZX210H-3.....	16 400 kg with 600 mm reinforced shoes
ZX210LCH-3	16 800 kg with 600 mm reinforced shoes
ZX210K-3	17 100 kg with 600 mm reinforced shoes
ZX210LCK-3.....	17 500 kg with 600 mm reinforced shoes

SERVICE REFILL CAPACITIES

	liters
Fuel tank	400.0
Engine coolant	26.0
Engine oil	23.0
Swing device	6.2
Travel device	6.8
(each side)	
Hydraulic system	240.0
Hydraulic oil tank	135.0

BACKHOE ATTACHMENTS

Boom and arms are of welded, box-section design. 5.68 m boom, and 2.42 m and 2.91m arms are available.
Bucket is of welded steel structure. Side clearance adjust mechanism provided on the bucket joint bracket.

BUCKETS

Capacity		Width		No. of teeth	Weight	Recommendation						
SAE, PCSA heaped	CECE heaped	Without side cutters	With side cutters			ZX200-3		ZX200LC-3		ZX210H-3 ZX210LCH-3	ZX210K-3 ZX210LCK-3	
						2.42 m arm	2.91 m arm	2.42 m arm	2.91 m arm	2.91 m H-arm	2.91 m K-arm	
0.51 m ³	0.45 m ³	720 mm	830 mm	3	530 kg	⊙	⊙	⊙	⊙	⊙	⊙	⊙
0.80 m ³	0.70 m ³	1 030 mm	1 140 mm	5	660 kg	⊙	⊙	⊙	⊙	⊙	⊙	⊙
0.91 m ³	0.80 m ³	1 150 mm	1 260 mm	5	700 kg	⊙	○	⊙	⊙	○	⊙	○
1.10 m ³	0.90 m ³	1 330 mm	1 440 mm	6	770 kg	□	—	□	○	—	○	○
1.20 m ³	1.00 m ³	1 450 mm	—	6	690 kg	□	—	□	—	—	—	—
0.80 m ³	0.70 m ³	1 030 mm	1 140 mm	5	750 kg	⊙	⊙	⊙	⊙	⊙	⊙	⊙
¹ 0.91 m ³	0.80 m ³	1 150 mm	1 260 mm	5	800 kg	⊙	○	⊙	⊙	○	⊙	○
² 0.80 m ³	0.70 m ³	1 040 mm	1 150 mm	5	760 kg	⊙	⊙	⊙	⊙	⊙	⊙	⊙
³ 0.80 m ³	0.70 m ³	1 030 mm	1 140 mm	5	660 kg	⊙	⊙	⊙	⊙	⊙	⊙	⊙
⁴ 0.80 m ³	0.70 m ³	1 040 mm	1 150 mm	5	760 kg	⊙	⊙	⊙	⊙	⊙	⊙	⊙
⁵ 0.60 m ³	0.50 m ³	800 mm	—	3	950 kg	●	—	●	—	—	—	—
One-point ripper				1	540 kg	●	—	●	—	—	—	—
Slope-finishing blade: Width 1 100 mm, length 1 800 mm				—	590 kg	◇	◇	◇	◇	◇	◇	—
V shape Bucket:				—	520 kg	○	○	○	○	○	—	—
Center-pull type clamshell bucket: 0.60 m ³ (CECE heaped), Width 940 mm				—	1 130 kg	⊙	⊙	⊙	⊙	⊙	⊙	⊙
Shell-push type clamshell bucket: 0.60 m ³ (CECE heaped), Width 870 mm				—		⊙	⊙	⊙	⊙	⊙	⊙	⊙

- ¹ Reinforced bucket
- ² H-bucket
- ³ Level-pin-type reinforced bucket
- ⁴ Super V teeth type reinforced bucket
- ⁵ Ripper bucket

- ⊙ Suitable for materials with density of 2 000 kg/m³ or less
- Suitable for materials with density of 1 600 kg/m³ or less
- Suitable for materials with density of 1 100 kg/m³ or less
- Heavy-duty service
- ◇ Slope-finishing service
- Not applicable

DIMENSIONS

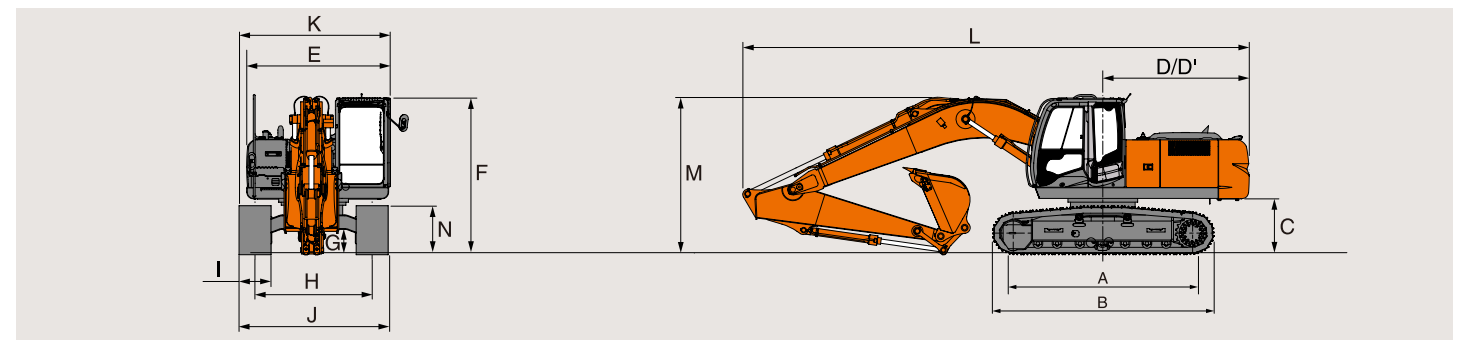

Unit: mm

	ZX200-3	ZX200LC-3	ZX210H-3	ZX210LCH-3	ZX210K-3	ZX210LCK-3
A Distance between tumblers	3 370	3 660	3 370	3 660	3 370	3 660
B Undercarriage length	4 170	4 470	4 170	4 470	4 170	4 470
* C Counterweight clearance	1 030	1 030	1 030	1 030	1 030	1 030
D Rear-end swing radius	2 750	2 750	2 750	2 750	2 750	2 750
D' Rear-end length	2 750	2 750	2 750	2 750	2 750	2 750
E Overall width of upperstructure	2 710	2 710	2 710	2 710	2 710	2 710
F Overall height of cab	2 950	2 950	2 950	2 950	3 080	3 080
* G Min. ground clearance	450	450	450	450	450	450
H Track gauge	2 200	2 390	2 200	2 390	2 200	2 390
I Track shoe width	G 600	G 600	G 600	G 600	G 600	G 600
J Undercarriage width	2 800	2 990	2 800	2 990	2 800	2 990
K Overall width	2 860	2 990	2 860	2 990	2 860	2 990
L Overall length						
With 2.42 m arm	9 605	9 605	9 605	9 605	9 605	9 605
With 2.91 m arm	9 520	9 520	9 520	9 520	9 520	9 520
With 4.41 m arm	9 420	9 420	9 420	9 420	9 420	9 420
M Overall height of boom						
With 2.42 m arm	3 180	3 180	3 180	3 180	3 180	3 180
With 2.91 m arm	2 940	2 940	2 940	2 940	2 940	2 940
With 4.41 m arm	3 510	3 510	3 510	3 510	3 510	3 510
N Track height with triple grouser shoes	920	920	920	920	920	920

* Excluding track shoe lug G: Triple grouser shoe

WORKING RANGES

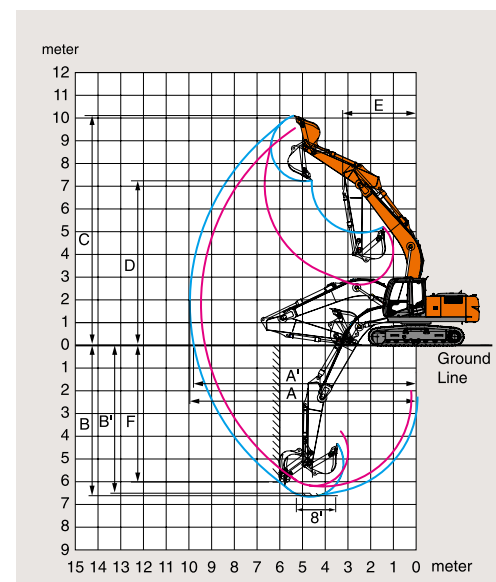

Unit: meter

Arm length	ZX200-3 / ZX200LC-3		ZX210H-3 / ZX210LCH-3	ZX210K-3 / ZX210LCK-3
	2.42 m	2.91 m	5.68 m H-boom 2.91 m H-arm	5.68 m K-boom 2.91 m K-arm
A Max. digging reach	9 430	9 920	9 920	
A' Max. digging reach (on ground)	9 250	9 750	9 750	
B Max. digging depth	6 180	6 670	6 670	
B' Max. digging depth (8' level)	5 950	6 490	6 490	
C Max. cutting height	9 670	10 040	10 040	
D Max. dumping height	6 830	7 180	7 180	
E Min. swing radius	3 280	3 180	3 180	
F Max. vertical wall	5 300	5 990	5 990	
Bucket digging force* ISO	151 kN (15 400 kgf)			
Bucket digging force* SAE : PCSA	129 kN (13 200 kgf)			
Arm crowd force* ISO	133 kN (13 600 kgf)	109 kN (11 100 kgf)	109 kN (11 100 kgf)	
Arm crowd force* SAE : PCSA	124 kN (12 700 kgf)	102 kN (10 400 kgf)	102 kN (10 400 kgf)	

Excluding track shoe lug * At power boost

STANDARD EQUIPMENT

Standard equipment may vary by country, so please consult your Hitachi dealer for details.

ENGINE

- H/P mode control
- E mode control
- 50 A alternator
- Dry-type air filter with evacuator valve (with air filter restriction switch for monitor)
- Cartridge-type engine oil filter
- Cartridge-type fuel double filters
- Air cleaner double filters
- Radiator, oil cooler and intercooler with dust protective net
- Radiator reserve tank
- Fan guard
- Isolation-mounted engine
- Auto-idle system
- Fuel cooler
- Electrical fuel feed pump
- Engine oil drain coupler

HYDRAULIC SYSTEM

- Work mode selector
- Power boost
- Auto power lift
- Extra port for control valve
- Suction filter
- Full-flow filter
- Pilot filter
- Swing dampener valve

CAB

- CRES II (Center pillar reinforced structure) cab
- OPG top guard fitted Level I (ISO10262) compliant cab
- All-weather sound suppressed steel cab
- Equipped with reinforced, tinted (green color) glass windows
- Upper front window can be opened
- 4 fluid-filled elastic mounts
- Intermittent windshield wipers
- Front window washer
- Adjustable reclining seat with adjustable armrests
- Footrest
- Electric double horn
- AM-FM radio with digital clock
- Auto control air conditioner
- Retractable seat belt
- Drink holder
- Cigarette lighter
- Ashtray
- Storage box
- Glove compartment
- Floor mat
- Short wrist control levers
- Pilot control shut-off lever
- Engine shut-off switch

MONITOR SYSTEM

- Display of meters: water temperature, hour, fuel rate, clock
- Other displays: work mode, auto-idle, glow, rearview monitor (when optional rear view camera is equipped), operating conditions, etc
- Alarms: overheat, engine warning, engine oil pressure, alternator, minimum fuel level, hydraulic filter restriction, air filter restriction, work mode, overload, etc
- Alarm buzzers: overheat, engine oil pressure, overload

LIGHTS

- 2 working lights

UPPERSTRUCTURE

- Undercover
- 4 350 kg counterweight
- Fuel level float
- Hydraulic oil level gauge
- Tool box
- Utility space
- Rear view mirror (right & left side)
- Swing parking brake

UNDERCARRIAGE

- Travel parking brake
- Travel motor covers
- 1 track guard (each side) and hydraulic track adjuster
- Bolt-on sprocket
- Upper and lower rollers
- Reinforced track links with pin seals
- 4 tie down hooks
- 600 mm triple grouser shoes

FRONT ATTACHMENTS

- HN bushing
- WC (tungsten-carbide) thermal spraying
- Reinforced resin thrust plate
- Flanged pin
- Casted bucket link A
- Centralized lubrication system
- Dirt seal on all bucket pins
- Bucket clearance adjust mechanism
- 2.91 m arm
- 0.80 m³ (SAE, PCSA heaped) bucket

MISCELLANEOUS

- Standard tool kit
- Lockable machine covers
- Lockable fuel refilling cap
- Skid-resistant tapes, plates and handrails
- Travel direction mark on track frame
- Onboard information controller
- Theft deterrent system

OPTIONAL EQUIPMENT

Optional equipment may vary by country, so please consult your Hitachi dealer for details.

- Suspension seat
- Hose rupture valves
- Electric fuel refilling pump with auto stop
- Swing motion alarm device with lamps
- Travel motion alarm device
- Rear view camera
- Additional pump
- Transparent roof
- Pre-cleaner

- Tropical cover
- Attachment basic piping
- Accessories for breaker
- Accessories for breaker & crusher
- Accessories for 2 speed selector
- Rear light

- Front glass lower guard
- Front glass upper guard
- K-cab (CRES II cab with overhead window and guard)
- 600 mm reinforced triple grouser shoes
- Full track guard
- Additional work light (boom right side)
- Additional light (on the top of the cab)
- 12 V power source
- Assist piping
- Pilot accumulator
- Rain guard
- Front screen of fuel cooler and air condenser

ZX210H-3 / ZX210LCH-3
(Heavy-duty version)

- 5.68 m H-boom and 2.91 m H-arm
- Damage prevention plate and square bars
- 0.80 m³ (SAE, PCSA heaped) H-reinforced bucket
- Reinforced link B
- Front glass lower guard
- 6.0 mm thickness undercover
- 4 750 kg counterweight
- 600 mm reinforced triple grouser shoe
- Reinforced track guard (2 units each side)
- Reinforced lower flange
- Reinforced idler bracket
- Reinforced side steps (bolt mounted)
- Auto control air conditioner

ZX210K-3 / ZX210LCK-3
(Demolition version)

- K-cab (CRESII cab with overhead window and guard)
- 5.68 m K-boom and 2.91 m K-arm
- 0.80 m³ (SAE, PCSA heaped) K-reinforced bucket
- Reinforced link B for demolition
- Reinforced bucket cylinder
- Front glass lower guard
- Twin wiper
- Attachment basic piping
- Damage prevention plate
- 6.0 mm thickness undercover
- Track undercover
- 600 mm reinforced triple grouser shoe
- 5 350 kg counterweight
- High-performance full-flow filter (with restriction indicator)
- Front screen of fuel cooler and air condenser
- Reinforced lower flange
- Reinforced idler bracket
- Reinforced side step (bolt mounted)

These specifications are subject to change without notice.
Illustrations and photos show the standard models, and may or may not include optional equipment, accessories, and all standard equipment with some differences in color and features.
Before use, read and understand the Operator's Manual for proper operation.

